



KERNLOCHBOHRER[®]
PROFESSIONAL POWER TOOLS



Operating instructions

Telescopic drill rig

TBS-3000/PRO

Kernlochbohrer GmbH
Geigersbühlweg 52
72663 Großbettlingen
Tel. 07022-5034900
E-Mail: info@kernlochbohrer.com

Version 0 3. Output 05/2023

Content

Introduction and description	3
Thanks to the buyer	3
Explanation of symbols	3
Safety regulations	4
Product description	7
Technical data	8
Assembly and drilling	8
Pflege und Wartung	10
Maintenance and inspection plan	11
Troubleshooting	12
Exploded view	13
Environmental protection	16
Warranty	16
EC Declaration of Conformity	17

Introduction and description

The telescopic drill stand TBS-3000/PRO is designed for mounting diamond core drills. This is intended for professional use and may only be used by trained personnel.

In the event of violations of the operating instructions which may lead to injuries or machine damage, our company declines all responsibility. In addition, all currently applicable regulations of the Accident Prevention Regulations (UVV) and the Employer's Liability Insurance Association (BG) must be observed.

Thanks to the buyer

Thank you for purchasing a telescopic drill stand from Kernlochbohrer GmbH. Please read the operating instructions carefully and observe the safety instructions. By operating it correctly, you will fully appreciate the outstanding performance of our products. Keep this manual in a safe place for future reference. If you have any questions about the operation of the telescopic drill rig, please contact Kernlochbohrer GmbH directly. We are always available to answer your questions.

Note:

Kernlochbohrer GmbH reserves the right to change the design and appearance of the products and their operating instructions. Future changes to the operating instructions will be made without prior notice.

Explanation of symbols



Warning of general danger. Failure to observe these safety precautions and instructions may result in electric shock, fire and/or serious injury.

Safety regulations

- ❖ Read all precautions before commissioning and keep the operating instructions.
- ❖ Please follow the operating instructions carefully, as failure to observe these safety precautions and instructions may cause electric shock, fire and/or serious injury.

1. Keep your work area clean and well lit. Disorder or unlit work areas can lead to accidents.
2. Do not work with power tools, near flammable liquids, gases or dust. Power tools produce sparks that can ignite dust or fumes, causing explosions.
3. Keep children and other people away from tools while using them. If you are distracted, you may lose control of the tool.
4. Be attentive, work with concentration and pay attention to what you are doing. Do not use a power tool when you are tired or under the influence of drugs, alcohol or medicines. A moment of inattention can lead to serious injury.
5. Wear suitable protective equipment and always safety glasses. Wearing suitable protective equipment such as a dust mask, non-slip safety shoes, gloves, hard hat or hearing protection reduces the risk of injury.



6. Avoid unusual postures. Make sure you stand securely and keep your balance at all times. Do not work on a ladder. This will help you control the power tool in unexpected situations.
7. Wear appropriate clothing. Do not wear loose clothing or jewellery. Keep hair, clothing and gloves away from moving parts. Loose clothing, jewellery or long hair can be caught by moving parts.
8. The use of products such as cutters, grinders, drills that work sand or other material can generate dust and fumes that may contain hazardous chemicals. Check the type of material you are going to work on and use a suitable respirator.
9. Never work alone, always make sure that another person is nearby. Apart from being able to get help with assembling the drill, you can also get help if an accident should happen.
10. Never use a drill that is faulty. Carry out the maintenance and service instructions described in this manual. Some maintenance and service procedures must be carried out by trained and qualified personnel.
11. Before mounting the drill motor and drill, make sure that the stand is properly attached.
12. The drill stand must be fixed on a level and firm surface. Drilling with a loose and/or wobbling stand can lead to a dangerous situation.
13. The core drill rig serves the intended purpose of mounting the drill motor for drilling. All other uses that are not for the intended purpose are prohibited.

14. Note!

The drill motor should be compatible with the drill stand. Never use a drill bit that exceeds the maximum drill diameter of the power tool. The maximum drill diameter for use on the TBS-3000/PRO is 200 mm. The drill motor and drill stand must be compatible and must not exceed the specified values.

15. When using the drill stand for overhead drilling, a functional water collection ring must be used. Make sure that no water can get into the motor.
16. Check all moving and tensioned parts before use.
17. Only use original spare parts from Kernlochbohrer GmbH.
18. Non-approved spare parts and any modification are prohibited on our products.

Product description

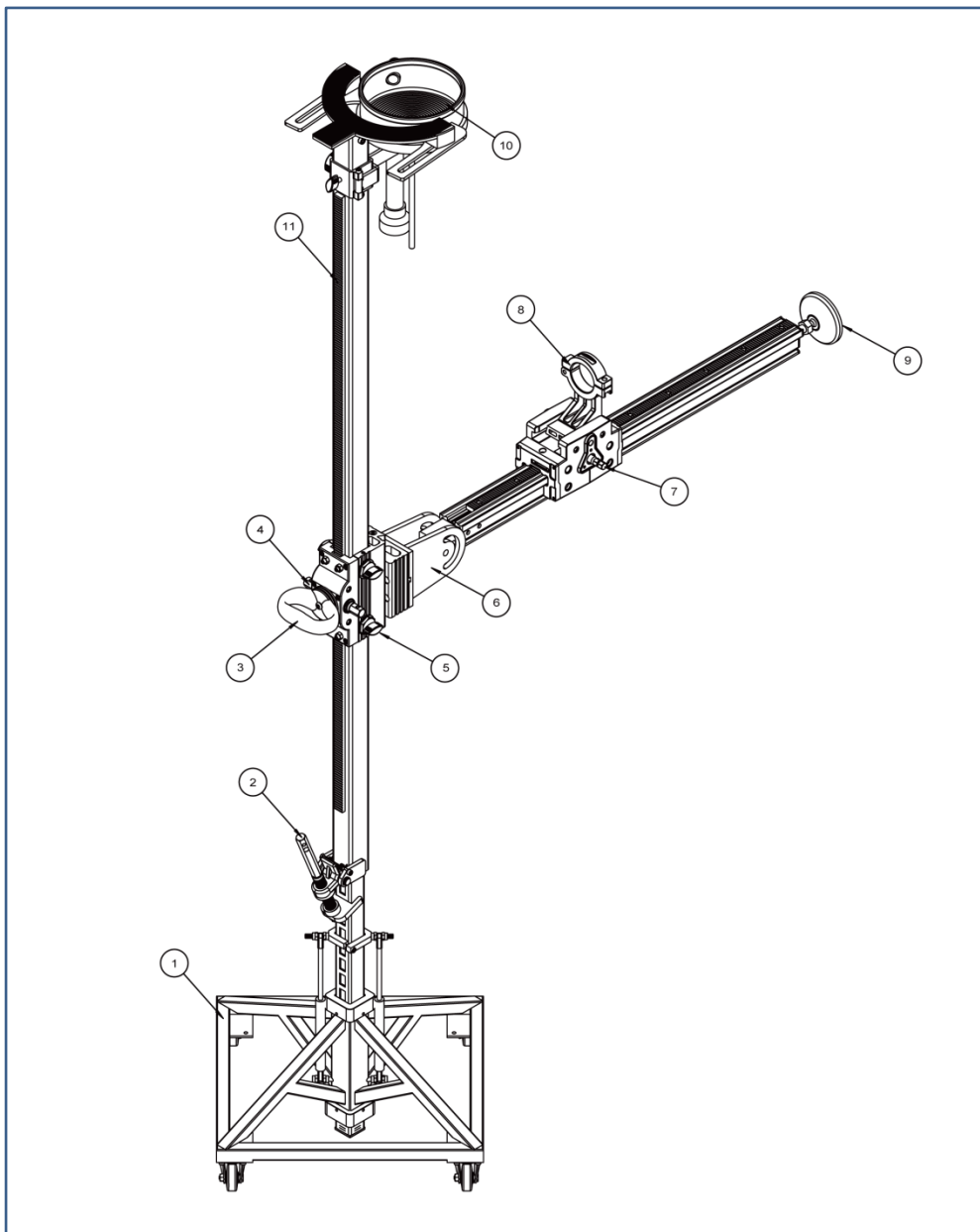

- | | | | |
|----|-------------------------|-----|-----------------------|
| 1. | Base frame | 7. | Drill slide |
| 2. | Quick-release lever | 8. | Ø 60mm clamp mount |
| 3. | Handle horizontal slide | 9. | Support foot |
| 4. | Horizontal slide | 10. | Water collection ring |
| 5. | Winged bonnet | 11. | Telescopic column |
| 6. | Angle clamp | | |

Technical data

Model:	TBS-3000/PRO
Article number:	6297
Max. Drill size:	200mm
Outer tube:	50x50x1700mm
Inner pipe:	40x40x1700mm
Drill column:	60x62x900mm
Drilling stroke:	1700-3000mm
Motor bracket:	60mm Adapter plate and Ø 60mm Clamp mount
Packaging size:	2290x580x670mm

Assembly and drilling

For horizontal and vertical drilling

Operate the quick-release lever (2) to move the telescopic column (11) up and down according to the ceiling height until the upper part of the stand is at the top and the lower part of the inner tube is at the bottom. Now brace the telescopic drill stand using the hand crank on the quick-release lever (2).

For vertical drilling, adjust the height of the drill column to your desired working position.

Turn the support foot (9) until it sits perfectly on the surface of the wall. If angle drilling is required, first loosen the wing screw (5) and adjust the drill arm to the desired angle, then retighten the wing screw (5). The support foot (9) must also be clamped to the wall.

Use either the Ø 60 mm clamp bracket (8) to mount the core drill on it or the matching adapter plate to the corresponding core drill. Make sure that the core drill is securely fastened on the drill slide (7).

Now the drill bit can be mounted on the machine. Note that the maximum designed drilling diameter for the TBS-3000/PRO is 200mm.

Crank the spindle on the drill slide (7) of the drill column to start drilling.

For ceiling drilling

Operate the quick release lever (2) to move the telescopic column (11) up and down according to the ceiling height until the upper part of the stand is at the top and the lower part of the inner tube is at the bottom. Set the centre of the drill using the centre point at the end of the telescopic drill stand. Now clamp the telescopic drill stand with the help of the hand crank on the quick-release lever (2).

For ceiling drilling, first loosen the wing cover (5) and set the drill column vertically. The height of the drill column must be adjusted so that the support foot (9) lies flat against the ceiling. Then tighten the wing screw (5) again. The support foot (9) must now also be clamped to the ceiling.

Use either the Ø 60 mm clamp bracket (8) to mount the core drill on it or the matching adapter plate to the corresponding core drill. Make sure that the core drill is securely fastened on the drill carriage (7).

Now the core bit can be mounted on the machine. Note that the maximum designed drilling diameter for the TBS-3000/PRO is 200mm.

Crank the drill slide (4) on the drill column of the telescopic column to start drilling the ceiling. Make sure that a water collection ring (10) is used when drilling the ceiling.

Care and maintenance

Repairs may only be carried out by qualified personnel who are suitable due to their training and experience. The telescopic drill stand is designed to require a minimum of care and maintenance. However, the following point must always be observed:

- After finishing the drilling work, clean the telescopic drill stand from dirt and dust and grease the stand if necessary for easier operation.
- After finishing work with the stand, grease the needle roller bearings and their threads. Make sure that no water runs out of the trolley and that there is no dust build-up on the trolley.
- If possible, do not use water to clean the drill stand, as some metal parts can accumulate flash rust and this can lead to malfunction. Make sure that the drill stand is dry after use and cleaning.
- In the front area of the drill carriage there are 4 rollers. In the rear area there are 4 eccentric clamps. In the course of time, the rollers may become worn. If this is the case, tighten the 4 eccentric clamps slightly until the slide can be moved again without play. If it is no longer possible to readjust the eccentric clamps, all 4 track rollers must be replaced to ensure no further damage to the gear shafts and the gear rack.
- Always pay attention to the wear and tear listed above. Replace the rollers and/or the eccentric clamps if necessary. If the problem still persists, replace the drill column.
- Check the stability of the drill stand before each use. If the base plate of the drill stand is damaged, replace it before using the drill stand.
- Carry out a visual and functional check regularly to ensure that all terminals and moving parts are fully functional.
- Failure to comply with this specification may result in malfunction during operation of the drill rig as well as injury to the operator.

Maintenance and inspection plan

Regular inspection according to the maintenance and inspection schedule is urgently required. Shorten the intervals between maintenance if you use the product very frequently.

Maintenance parts	each time before use	monthly or after 25 hours of work	Every 3rd month or after 50 hours of work	annually or after 200 working hours
Greasing the needle bearing of the gear shaft	√	√	√	√
Lever-locking device	√	√	√	√
Clamping and wheels	-	√	√	√
Drill column	-	-	-	√
Gear shaft and gears	-	-	-	√
All clamping parts and threads	√	√	√	√
Rack	-	√	√	√
Base plate welds	-	√	√	√

Troubleshooting

Error	Cause	Troubleshooting
the carriage wobbles	Tensioner worn	Retighten the 4 eccentric clamps.
the gear shaft jams	All 4 rollers worn	Replace all 4 castors.
Runout of the drive shaft on the rack	Wear on the gear shaft or rack.	Replace the worn part.
carriage lever lock cannot engage on the gear rack	The lever lock has deformed or the weld is coming loose.	Replace the lever lock.
After replacing all eccentric clamps and aligning the impellers, the movement of the slide is still unreliable.	The drill column is worn.	Replace the drill column.
Drill motor cannot be clamped	Wear on the clamping surface	Replace the clamping bracket $\varnothing 60\text{mm}$.
Drill column starts to wobble slightly	Crack at the weld seam of the base plate to the column holder.	Replace the base plate of the drill stand.

Exploded view

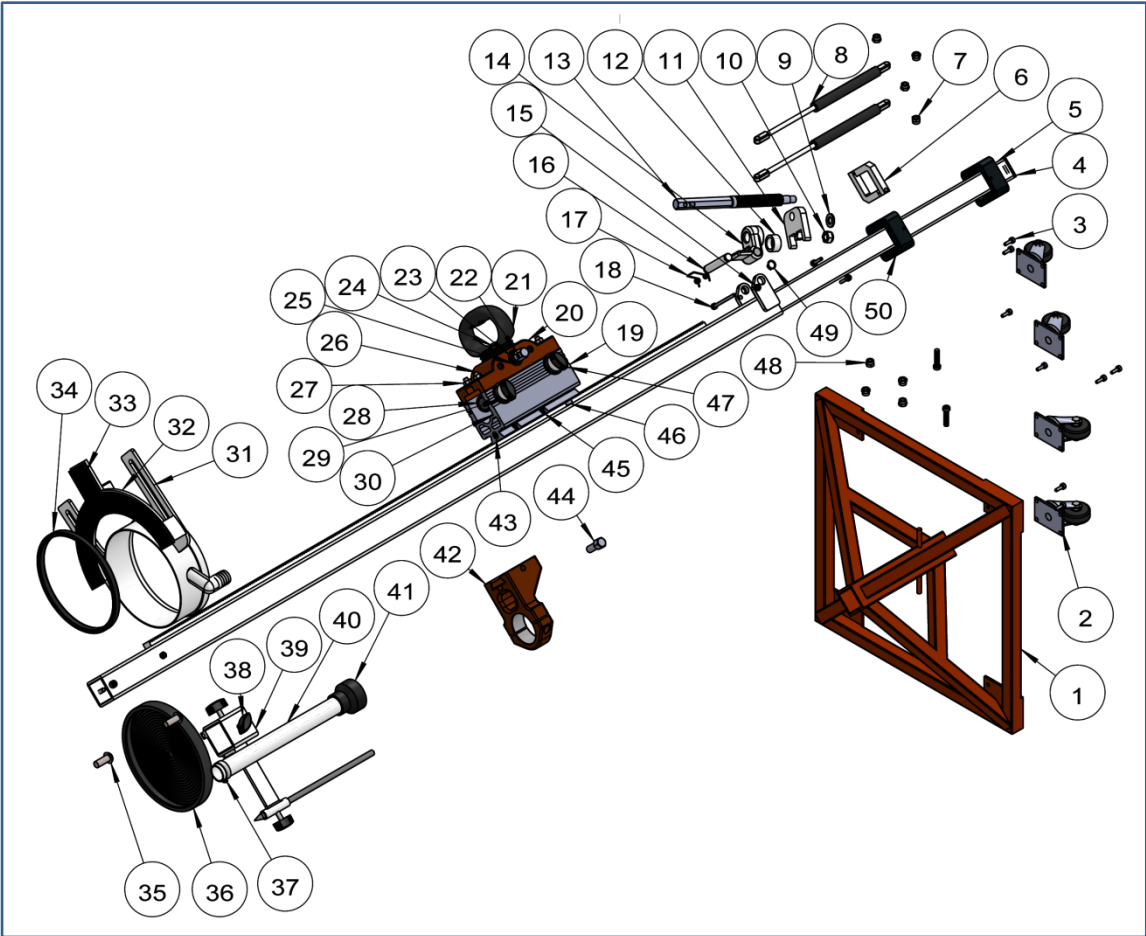

No.	Designation	Number	No.	Designation	Number
1	Telescopic column base	1	26	Hexagon socket screw M8x20	4
2	4" Silent rubber wheel	4	27	Hexagon socket screw M8	4
3	Hexagon socket screw M6x12	16	28	Slot nut #1	4
4	Square tube plug cap 40x40	1	29	Aluminium hexagon head screw	4
5	Inner tube of the telescopic column 40x40x1800mm	1	30	Slot nut #2	2
6	Column holder	2	31	Dust cover	1
7	Cap nut M8	4	32	Dust-protected bracket	1
8	Gas spring L300	2	33	Anti-slip pad	1
9	Washer Φ 12	1	34	U-ring 12x6mm	1
10	Lock nut M12	1	35	Hexagon socket mushroom head screw M12x25	2
11	Positioning block	1	36	Water collection ring	1
12	Adjusting disc	1	37	Stainless steel hose clamp	1
13	Adjusting screw Rod	1	38	Plastic wing grip screw M8x20	3
14	Adjusting socket	1	39	Pilot pin assembly	1
15	Lock nut M6	2	40	Steel wire reinforced PVC hose Φ 32x300L	1
16	Positioning bolt D14x78	1	41	Vacuum hose coupling	1
17	Spring	1	42	Φ 60 Clamp bracket	1
18	Hexagon socket screw M6x80	1	43	Spirit level Φ 12x6mm	1
19	Slide	1	44	Locking screw M12x45	1
20	Gearbox assembly	1	45	Positioning block	2
21	Rubber handle	1	46	Hexagon socket screw M8x16	1
22	Shaft	1	47	Plastic wing grip screw M8x35	4
23	Circlip Φ 20	2	48	Spacer sleeve	4
24	Hexagon socket mushroom head screw M8x25	4	49	Circlip Φ 12	2
25	Copper sleeve	2	50	Rectangular tube holder	2

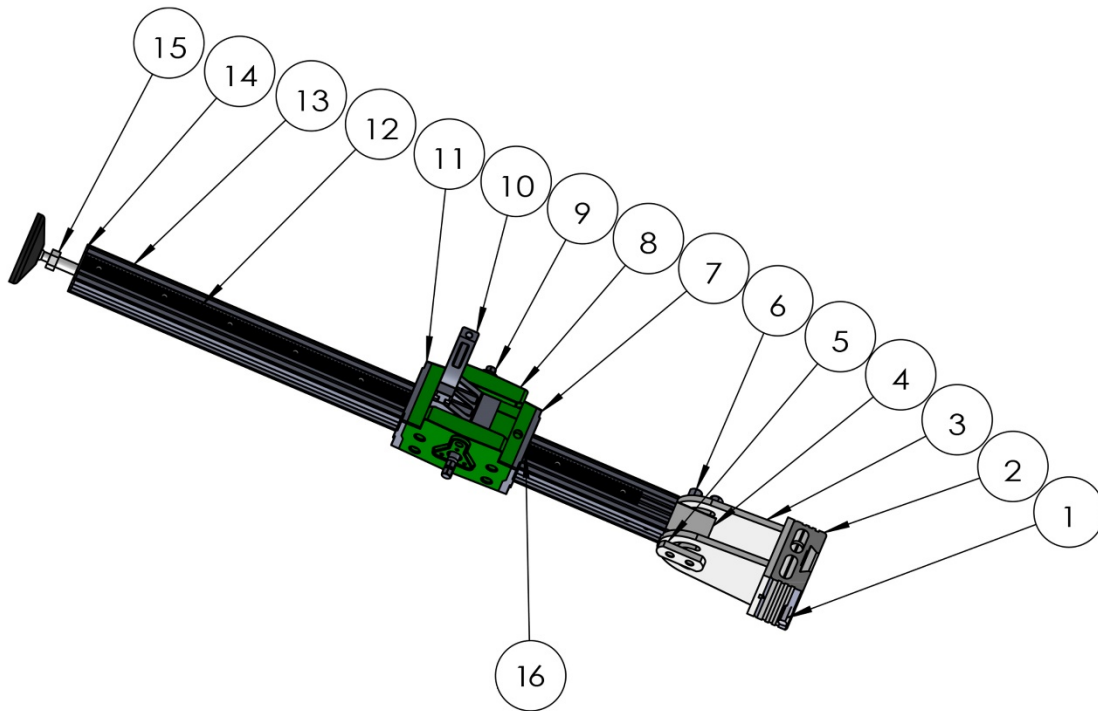

Transverse arm mounting of the DSP-3000

No.	Designation	Number	No.	Designation	Number
1	Locking screw M12x45	1	9	Crankshaft M1.5x11T	1
2	Cross arm mounting Spacer T=50mm	1	10	Φ60 Clamp bracket	1
3	Cross arm clamp	1	11	Lower slide guard	1
4	Rotatable mounting block	1	12	Rack L=900mm	1
5	Mounting block	1	13	Support arm column 50x50x900mm	1
6	Fixing screw M12x80	2	14	Support leg mounting plate	1
7	Slide protection top	1	15	Adjustable support leg M16	1
8	Slide DSP-162	1	16	Slide lever lock	1

Environmental protection

Raw material recovery instead of waste disposal!

To avoid transport damage, the unit must be delivered in sturdy packaging. Packaging as well as the unit and accessories are made of recyclable materials.

The plastic parts of the unit are labelled according to the material. This enables environmentally friendly, sorted disposal via the collection facilities offered.

Warranty

In accordance with our general terms and conditions of delivery, a warranty period of 12 months applies for material defects in business transactions with companies (proof by invoice or delivery note). Damage due to natural wear and tear, overloading or improper handling remains excluded from this. Wear parts such as the column, the tensioner and the locating wheels or needles etc. are excluded from the warranty. Damage caused by material or manufacturer defects will be remedied free of charge by repair or replacement. Complaints can only be accepted if the unit is sent to the supplier unassembled.

EC Declaration of Conformity

It is required that the machine operated in this drill rig (e.g. DKB-PRO series) complies with the requirements described in the technical data of the drill rig (e.g.: drill diameter, machine mounting). We hereby declare that this unit has been designed in accordance with Directive 2006/42/EC. Commissioning of this drilling unit is prohibited until it has been established that the power tool to be connected to this unit complies with the provisions of Directive 2006/42/EC (recognisable by the CE marking on the power tool).

Name and address of the person authorised to compile the technical documentation:

Kernlochbohrer GmbH
Geigersbühlweg 52
72663 Großbettlingen

Location: Großbettlingen
Date: 17.05.2023

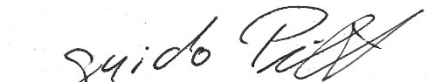

Guido Pillat
Chief Executive Officer